

IMPORTANT SAFETY PRECAUTIONS

Before you begin, read these instructions completely and carefully.

- Be certain electrical power is OFF before and during installation, maintenance and removal.
- Luminaire wiring must be properly grounded in accordance with the NEC and any applicable local code requirements.
- Use only UL or IEC approved wire for input/output connections.
- Verify that supply voltage matches voltage on luminaire label. Installation to any other connection may void the warranty.
- Wear gloves during installation to prevent injury and do not expose wiring to metal or sharp edges.
- Do not install in areas subject to combustible vapors or gases. Verify luminaire location ratings are suitable for installation environment (refer to specification sheet as needed).
- Do not restrict luminaire's ventilation by covering with material that will cause luminaire to overheat and potentially shorten the life span.
- Ensure LED luminaire has the correct polarity before installation.



WARNING: To reduce the risk of personal injury or property damage from fire, electrical shock, falling parts, abrasions, burns and all other hazards, read all provided warnings and follow installation instructions.

This product should be installed, inspected and maintained by a qualified and licensed electrician. Installation of luminaire must be in accordance with NEC and local code requirements.

SAVE THESE INSTRUCTIONS

DIMENSIONS

24W

32W

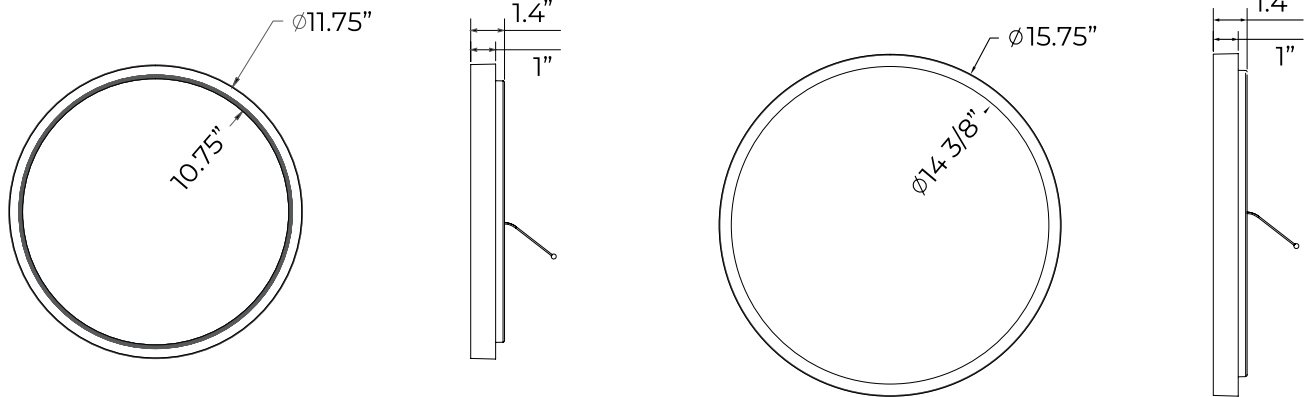

MOUNTING PLATE DRILL PATTERN

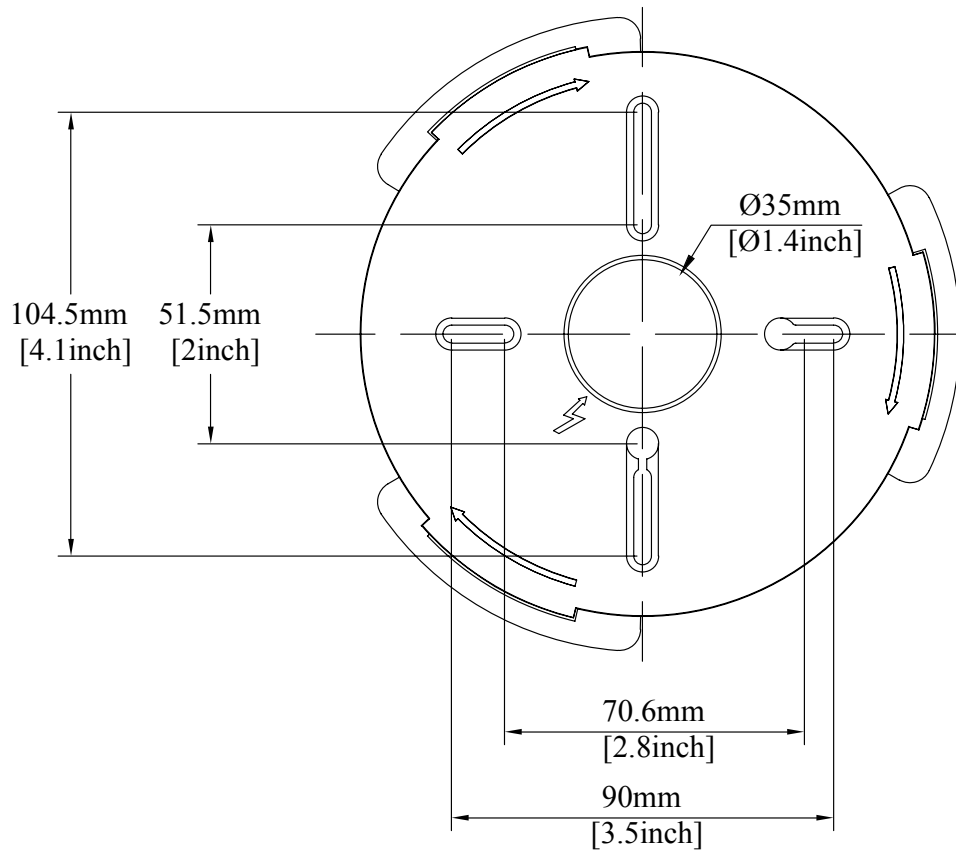

SAVE THESE INSTRUCTIONS

INSTALLATION INSTRUCTIONS

A) Rotate the mounting plate (Part B) counter clockwise to detach it from the lamp body (Part A).

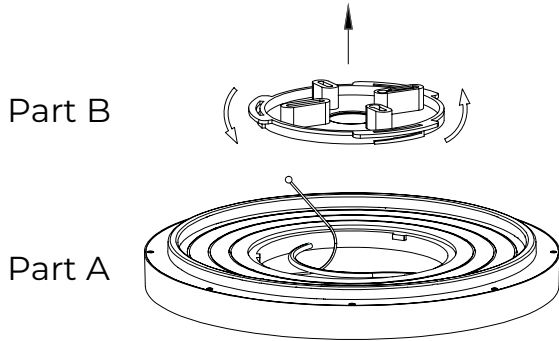

B) Install the mounting plate to the ceiling. There are two types installation:

For Junction Box mounting with flat screws
(Suitable for 2", 2.5", 3", 3.5", 4" J-Box)

Hard/drywall ceiling mounting with tapered screws and plastic anchors

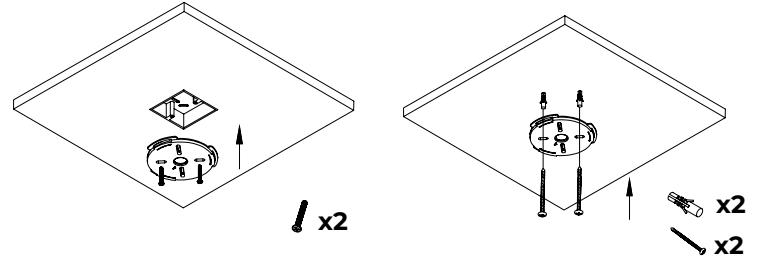

C) Connect the luminaire body safety cable to the mounting plate, then connect the wires with the wire nuts. Carefully place all the wires and wire connections into the junction box. Make sure no bare wire or wire strands are visible after making the connections. The luminaire body is made of insulating plastic, no need to connect the ground wire.

D) Match the alignment arrows as indicated on the mounting plate and the luminaire body. Install the luminaire body to the mounting plate by rotating clockwise.

E) Installation complete. 

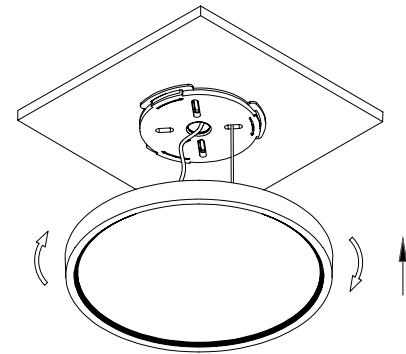
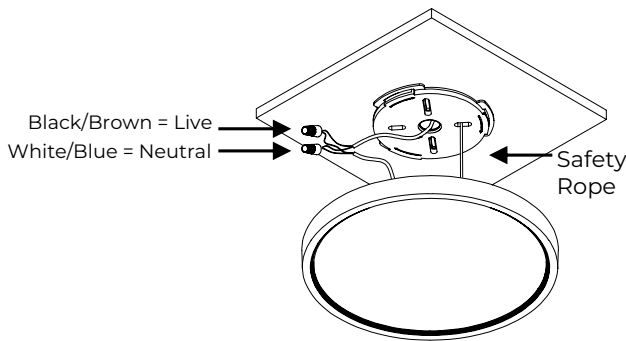

SAVE THESE INSTRUCTIONS

MOBILE APP SET-UP

A) Download App

Download App "Smart Life" from App Store or Google Play Store Or Scan the QR Code.



B) Registration

Tap "Registration" and "Agree", Follow the instruction and Finish registration, suggest to use Mobile number or E-mail with password for 3rd party Linked in the future

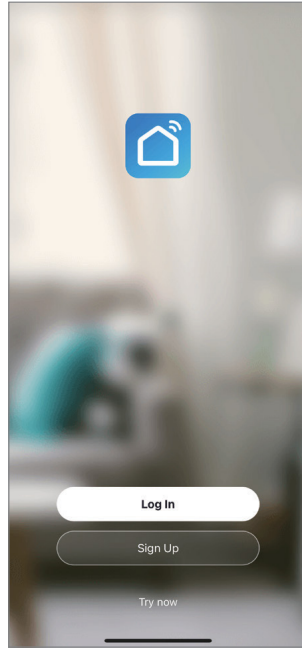

C) Pairing Devices

Turn on and turn off the lamp 2 times, then turn on after 4 Seconds, to go into pairing mode. Light will blink.

D) Tips before adding devices

- Make sure your smart phone or other device is connected to your home Wi-Fi 2.4GHz successfully. Make sure Bluetooth is on.



E) Go to the Home Page and tap "+" in the corner.

F) Under "Add Manually," select the corresponding product model pairing or "Auto Scan"

- You also can select Auto Scan Mode

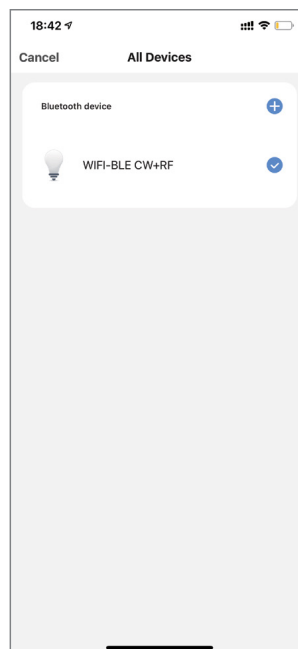
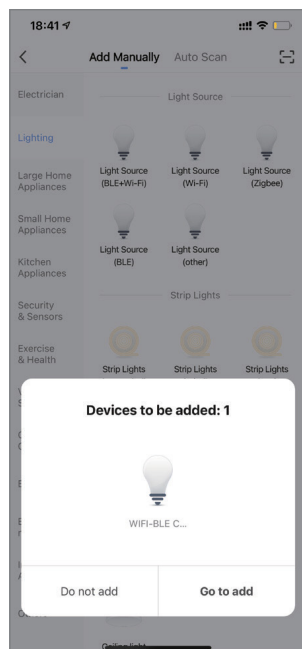
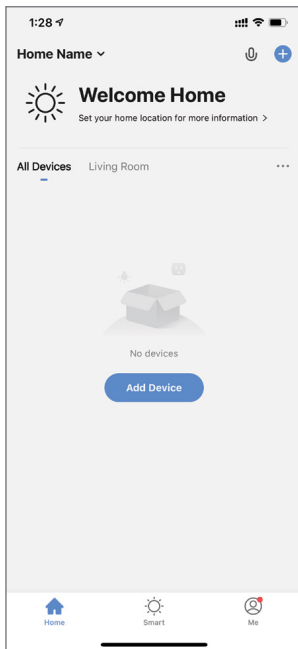

OR

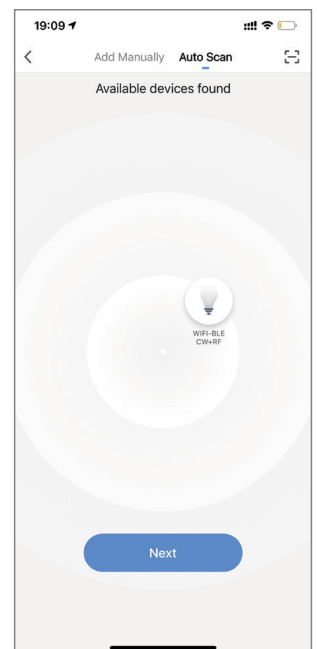

SAVE THESE INSTRUCTIONS

MOBILE APP SET-UP (CONTINUED)

G) Enter Wi-Fi password.

H) Connect equipment to Wi-Fi.

I) Rename fixture if desired.

J) Select "Control Panel"

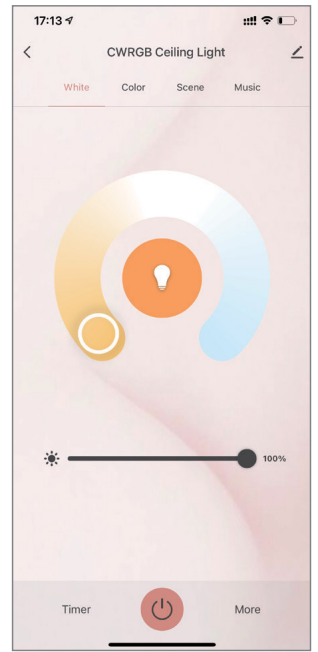
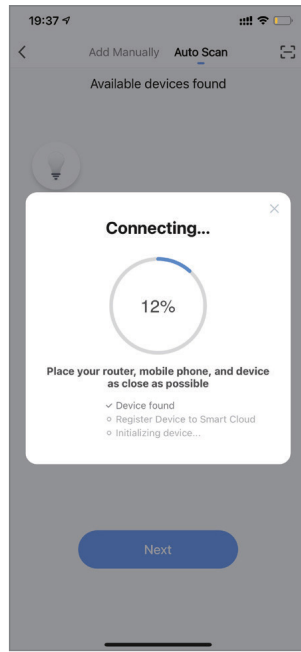
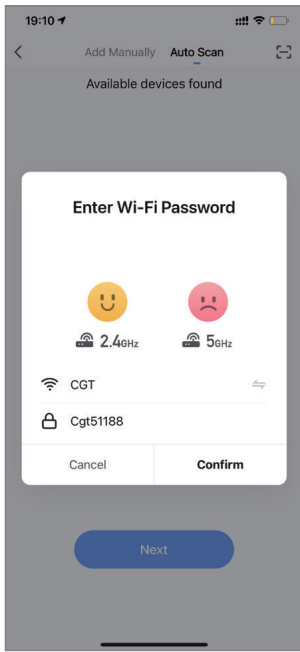

MOBILE APP OPERATION

A) Select "White" or "Color" to adjust the CCT and/or dim.

B) Select "Schedule" to set On/Off function for scheduling.

- Adjust to desired color temperature

- Add schedule and save. Repeat as desired.

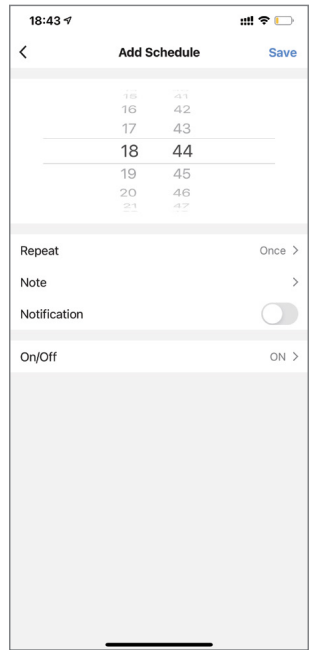
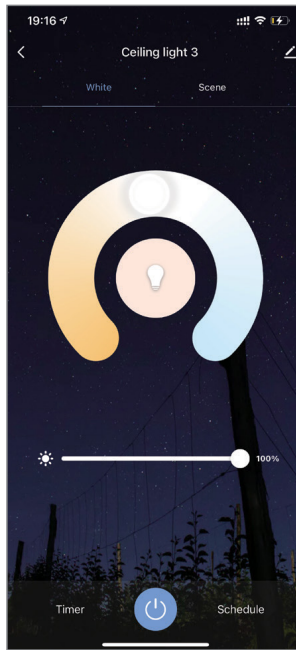
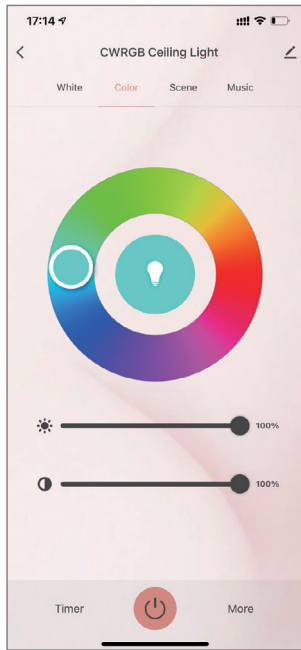
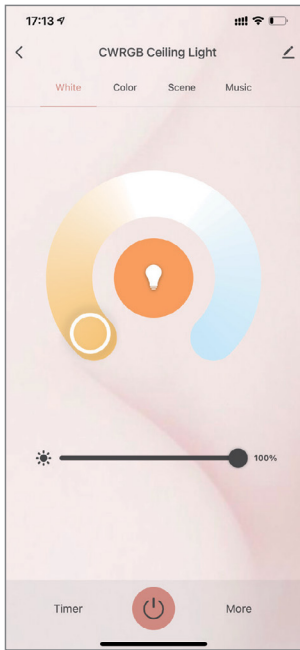

SAVE THESE INSTRUCTIONS

MOBILE APP OPERATION (CONTINUED)

C) Select "Timer" to set countdown timer. At the selected time, the light will automatically turn off.

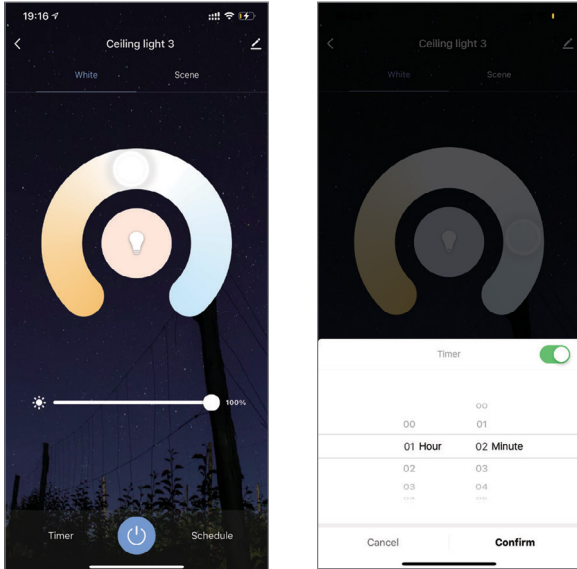

D) Group control

- Click  to enter the device details interface;
- Click 'Create Group' to enter the device sharing interface.

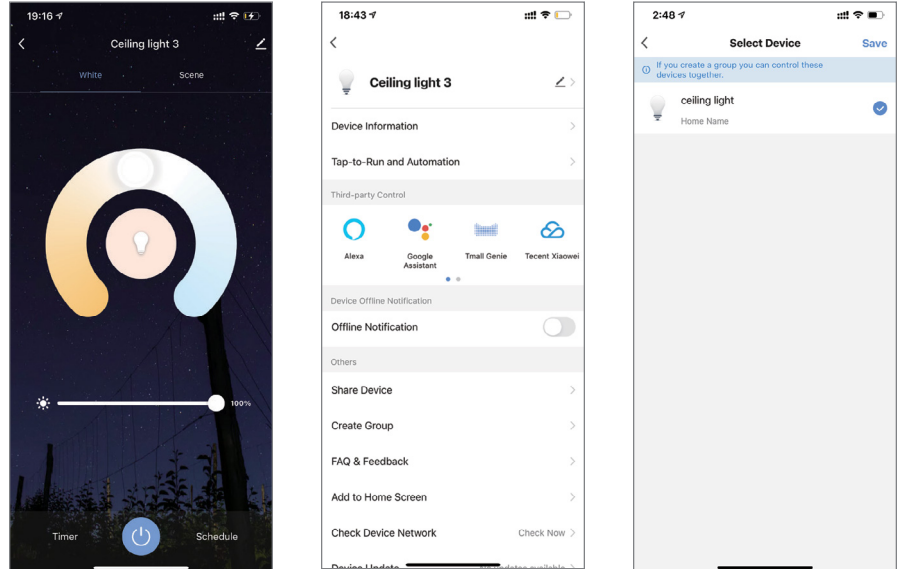

E) Home Manage.

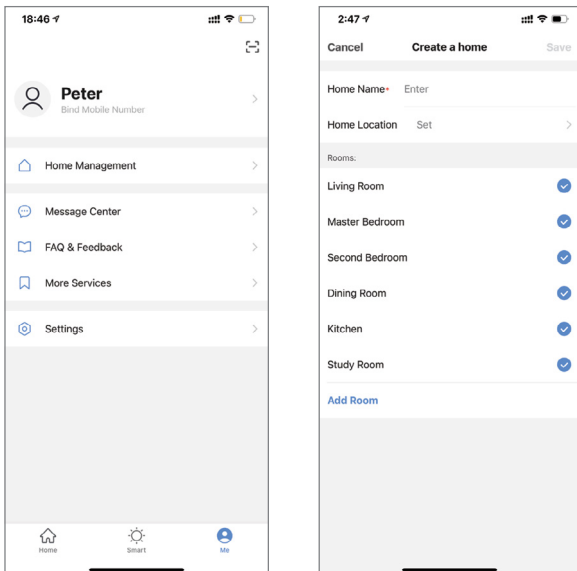

F) Troubleshooting

1. Please ensure the device is connected to power and your phone is connected to Wi-Fi.
2. Check routers: If the router is dual-band router, select a 2.4GHz network to add device. You may need to open the router broadcasting function.
3. Set up the wireless router: Set encryption method as WPA2-PSK, authorization type as AES, or set both as auto. The Wireless mode cannot be 5GHz. Please name router Wi-Fi in English. Ensure fixture is within Wi-Fi range.
4. Make sure router wireless MAC filtering is enabled.
5. Make sure the password is correct when adding a new device.

SAVE THESE INSTRUCTIONS

AMAZON ALEXA & GOOGLE HOME SET-UP

For Amazon Alexa

- Open Alexa App and select "Skills" from the top menu.
- On the Skills Page, search for 'Smart Life'.
- Enable Smart Life in the Alexa App.
- Log in with your Smart Life account (username & password)
- Discover new smart devices in the App or ask Alexa to Discover new devices.

For Google Home

- Open Google Home App, tap "+" icon in the homepage.
- Select "Set up device" in the "Add and Manage" screen.
- In the "Set Up" screen, select "New Devices" to set up new devices in your home.
- Select "Works with Google" to authorize Google Home to work with your Smart Life account.

AMAZON ALEXA & GOOGLE HOME VOICE CONTROL EXAMPLES

For Amazon Alexa

- Alexa, turn on <device name>
- Alexa, turn off <device name>
- Alexa, set <device name> to percent
- Alexa, brighten/increase <device name>
- Alexa, dim/decrease <device name>

For Google Home

- Hey Google, turn on <device name>
- Hey Google, turn off <device name>
- Hey Google, is <device name> on/off?
- Hey Google, brighten/increase <device name>
- Hey Google, Dim/Brighten <device name> by 50%

REMOTE CONTROL MANUAL

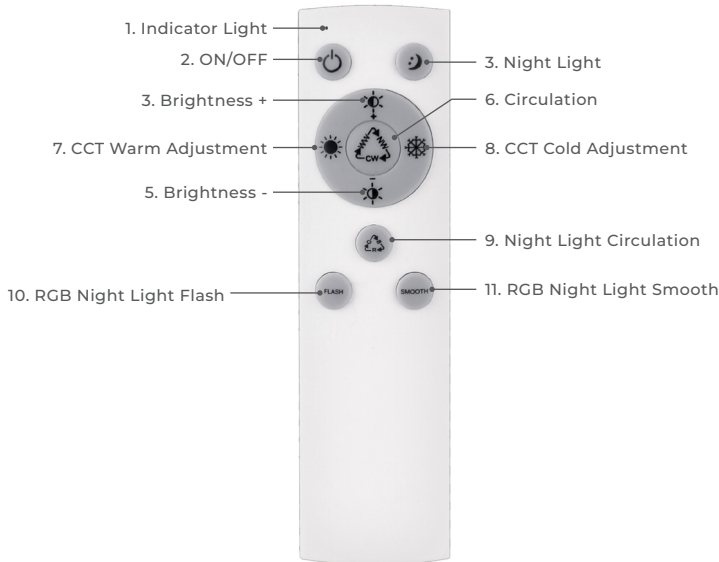

- 1) Indicator Light
- 2) OFF/ON
- 3) Night Light
- 4) Brightness +
- 5) Brightness -
- 6) Warm White/Nature white/Cold white-circulation
- 7) Color Temperature adjustment
 - From cold white to warm white
- 8) Color Temperature adjustment
 - From warm white to cold white
- 9) Green/ Red/Blue color night light-circulation
- 10) RGB night light Flash
- 11) RGB night light Smooth

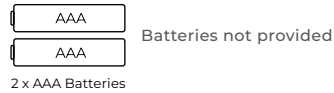

CLEAR CODE:

If light is not connected with app, remote control must be used.

Press and hold the "OFF/ON" button ② for 3 seconds till the indicator light ① on remote flashes; Then turn on the ceiling light, when the indicator light ① on the remote becomes steady on, it means code has been successfully cleared.

MATCH CODE:

1. If the ceiling light has been linked to remote control, it can only be controlled by the matched remote. Matching remote control to fixture ensures the designated remote control controls the matched fixture only.
2. You can match multiple lights to one remote up to 60 feet away.

Press and hold "NIGHT LIGHT" button ③ for 3 seconds till indicator light ① on the remote flashes; Then turn on ceiling light; when the indicator light ① on the remote becomes steady on, fixture has been successfully matched to remote control.

REMOTE CONTROL MANUAL (CONTINUED)



- 1) Indicator Light
- 2) OFF button
- 3) ON button
- 4) Brightness adjustment
 - Increase up to 100%
- 5) Brightness adjustment
 - Decrease down to 10%
- 6) Color Temperature adjustment
 - From cold white to warm white
- 7) Color Temperature adjustment
 - From warm white to cold white
- 8) Warm White/Nature white/Cold white -circulation
- 9) RGB night light Flash

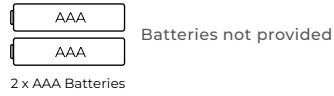

CLEAR CODE:

If the ceiling light has been removed code, it can be controlled by any of our remotes.

Press and hold the "OFF" button ② for 3 seconds till the indicator light ① on remote flashes; Turn on the ceiling light. If the indicator light ① on the remote stays on, it means code has been successfully cleared.

MATCH CODE:

1. If the ceiling light has been linked to remote control, it can only be controlled by the matched remote. Matching remote control to fixture ensures the designated remote control controls the matched fixture only.
2. You can match multiple lights to one remote up to 60 feet away.

Press and hold "ON" ③ for 3 seconds till indicator light ① on the remote flashes; Then turn on ceiling light; when the indicator light ① on the remote becomes steady on, fixture has been successfully matched to remote control.