



DUNTON HOUSE

DECORATIVE LIGHTING

BARS-QS FLUSH MOUNT LED QUICK SHIP

PROJECT DATE

COMMENTS



IN STOCK

PHYSICAL

Material	Aluminum/Steel Alloy
Mounting	Surface
Lens	Polycarbonate
Finish	Brushed Nickel
Source	LED

PERFORMANCE

Warranty	5 years
Certification	Energy Star, ETL, cETL
Rated Life	L70 50,000 hours
Operating Temperature	-20°C to 45°C (-4°F to 113°F)
CCT	Field Selectable 3CCT: 3500K, 4000K, 5000K
CRI	>90
Beam Angle	120°

ELECTRICAL

Wattage	20W, 25W
Voltage	120V
Power Factor	0.9
Dimmable	Triac

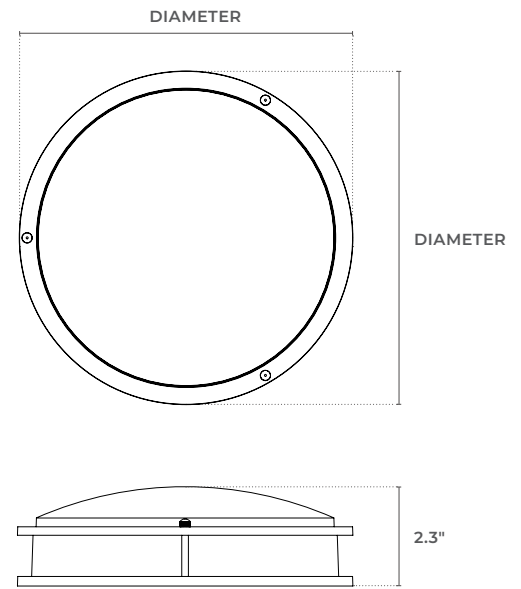

ENERGY CHART

DIAMETER inches	HEIGHT inches	DELIVERED LUMENS	WATTAGE	EFFICACY lm/w
14	2.3	1600	20	80
16	2.3	2000	25	80

ORDERING LOGIC

EX: BARS-QS-14-FS

FAMILY	DIAMETER	CCT
BARS-QS		FS
	14 14"	FS Field Selectable 3500K / 4000K / 5000K
	16 16"	