

# D-96W 96W CONSTANT VOLTAGE LED DRIVER 5 IN 1 DIMMING FUNCTION

PROJECT \_\_\_\_\_ DATE \_\_\_\_\_

COMMENTS \_\_\_\_\_



D-96W is a versatile 96W 5-in-1 universal dimming Class II driver that accepts 100-277VAC input voltage and provides 24VDC constant voltage output. D-96W delivers flicker free dimming to 0% on all dimming systems including Triac, 0-10V, 1-10V, PWM, Resistance, MLV, ELV and Incandescent. The high efficiency of the driver and sophisticated over-load protection enables the electronics to run cooler and significantly improve reliability while extending product life. The compact metal case is dry/damp location listed and IP65 rated, making it suitable for a wide range of indoor/outdoor architectural, commercial, industrial, and residential lighting applications. D-96W is available with or without integrated junction boxes on both the input and output side that have two knockouts each.



## PHYSICAL

Material	Metal
----------	-------

## PERFORMANCE

Warranty	5 years
Certifications	Dry/Damp Location, cULus, Class II, FCC, RoHS Compliant
IP Rating	IP65
Rated Life	50,000 hours
Operating Temp. Humidity	-40°C to 50°C; 20% - 95% RH
Storage Temp. Humidity	-40°C to 90°C; 10% - 95% RH
Dimming	5 in 1 Dimmable (0-10V, 1-10V, Triac, PWM, Resistance)
THD	<20%

## ELECTRICAL

Wattage	96W
Output Voltage	24VDC
Input Voltage	100-277VAC
Output Rated Current	4A
Input AC Current	115VAC - 0.61 A, 230VAC - 0.45 A, 277VAC - 0.38A
Power Factor	115VAC - 0.98, 230VAC - 0.95, 277VAC - 0.9
Minimum Efficiency	115VAC - 90, 230VAC - 92, 277VAC - 95
Output Frequency	10K Hz
Over Voltage	26 - 32V

## ORDERING LOGIC

EX: D-96W-JB

FAMILY	JUNCTION BOX
<b>D-96W</b>	<b>JB</b> Integrated Junction Box
	<b>NJB</b> No Junction Box

## SPECIFICATIONS

### OUTPUT

Output Voltage	24VDC
Rated Current	4A
Rated Power	96W
Ripple & Noise (Max.)	250mVp-p
Voltage Accuracy	±2.0%
Linear Adjustment Rate	±0.5%
Load Adjustment Rate	±0.5%
Start, Rise Time	500ms, 100ms/230VAC, 1000ms, 100ms/115VAC
Hold Time	10ms/115VAC, 230VAC

### PROTECTION

Over Current	95 ~ 110% Constant Current Limit, load abnormal condition can be removed after automatic recovery
Short Circuit	Burp mode, load abnormal conditions can be removed after automatic recovery
Over Voltage	26 ~ 32V, turn off the output voltage, restart and resume
Over Temperature	Turn off the output voltage, restart and resume

### INPUT

Voltage Range	100 ~ 277VAC
Frequency Range	47 ~ 63Hz
Power Factor	PF≥0.98/115VAC, PF≥0.95/230VAC, PF≥0.9 /277VAC, Full Load
Total Harmonic Distortion	THD< 20% (@ load ≥50%/115VC,230VAC; @ load ≥75%/277VAC)
Efficiency	≥90% (Vin: 115VAC), ≥92% (Vin: 230VAC)
AC Current	0.61A/115VAC 0.45A/230VAC
Inrush Current	Cold Start 75A(width=350us measured at 50% I peak)/230VAC
Leakage Current	< 0.5 mA

### ENVIRONMENT

Working Temp	T case= -40 ~ +50°C
Max. Case Temp	T case =+90°C
Working Humidity	20 ~ 95% RH, Non-Condensing
Storage Temp. Humidity	-40 ~ +90°C, 10 ~ 95% RH
Temp. Coefficient	±0.03%/°C (0 ~60°C)
Vibration	10~500Hz, 5G 12min./1 cycle, period for 72 min. each along X,Y,Z axes

### Note:

1. Unless otherwise specified, all specifications and parameters shall be measured at the input of 230VAC, rated load and ambient temperature of 25°C.
2. Accuracy: includes setting error, linear adjustment rate and load adjustment rate.
3. The start time is measured under the starting of the cold machine. Frequent switching on and off may increase the start time.
4. The driver is regarded as a component used in combination with the terminal equipment. Since the EMC is affected by the whole device, the manufacturer of the terminal equipment needs to reconfirm the EMC of the whole device.

## ADDITIONAL IMAGERY



**BLOCK DIAGRAM**

**5 IN 1 DIMMING FRAMEWORK SCHEMATIC (0-10V, 1-10V, PWM, RESISTANCE, TRIAC)**

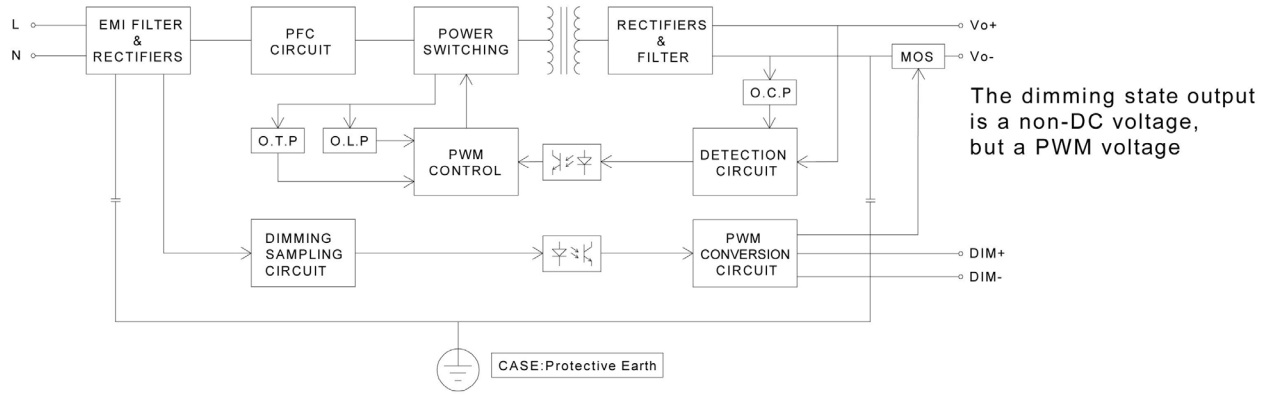

**DIMMING CONNECT DRAWING**

**TRIAC/PHASE-CUT**

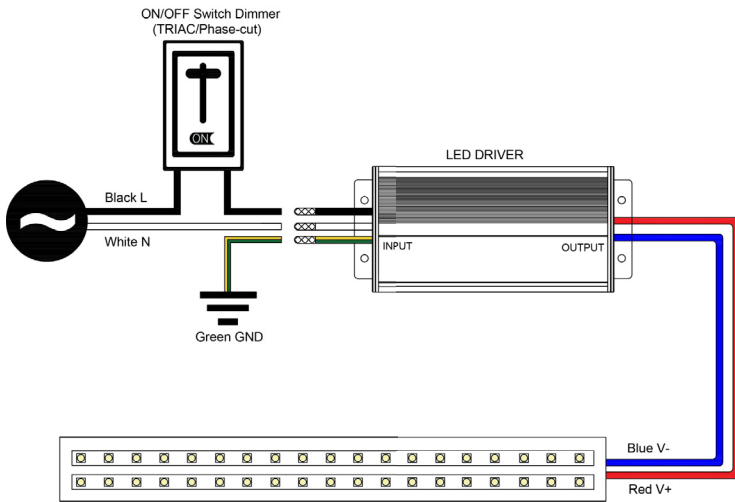

**1-10V**

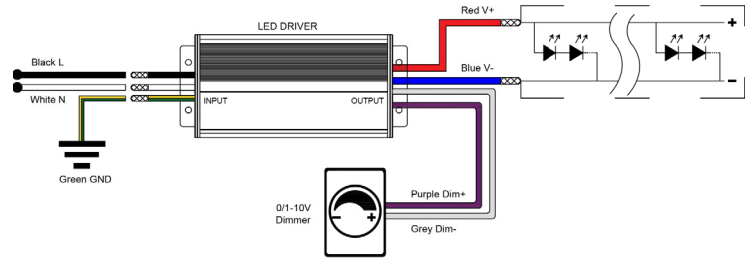

**PWM**

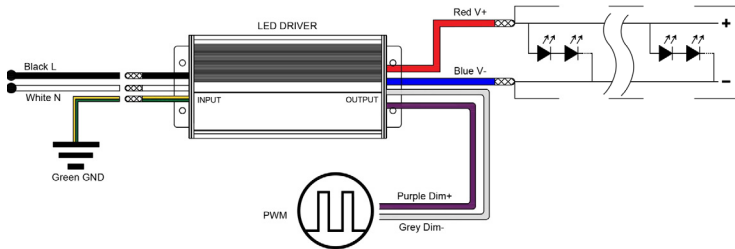

**RESISTANCE**

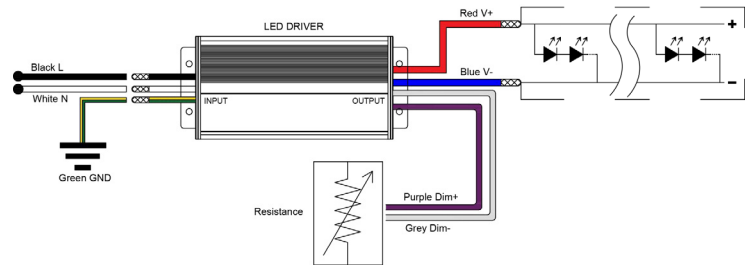

**Instructions:**

1. This driver should be installed by qualified and professional person;
2. Suitable for indoor use without direct sunlight exposure; Good ventilation are need;
3. Ensure that wiring is correct before test in order to avoid light damage;
4. If driver cannot work normally, don't maintain privately; Have any questions, please contact "Keysun"

**DIMMING CURVES**

**POWER FACTOR - OUTPUT POWER CURVE**

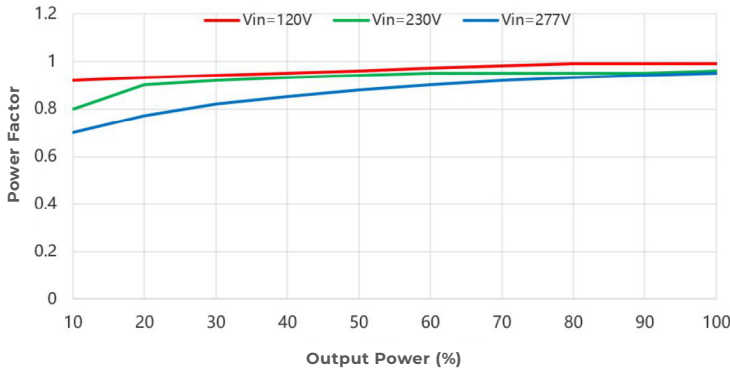

**OUTPUT - AMBIENT TEMPERATURE CURVE**

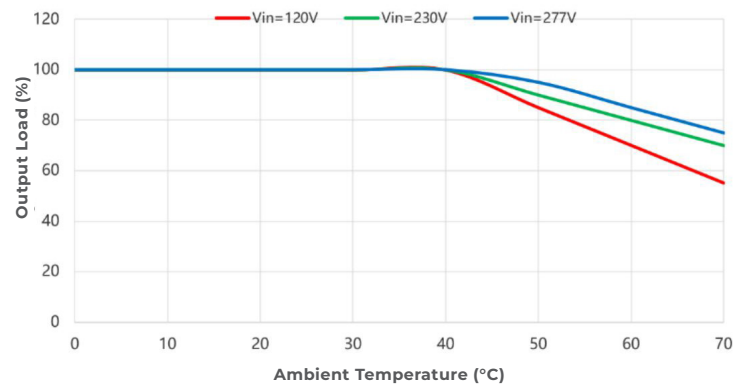

**LIFE - SHELL TEMPERATURE CURVE**

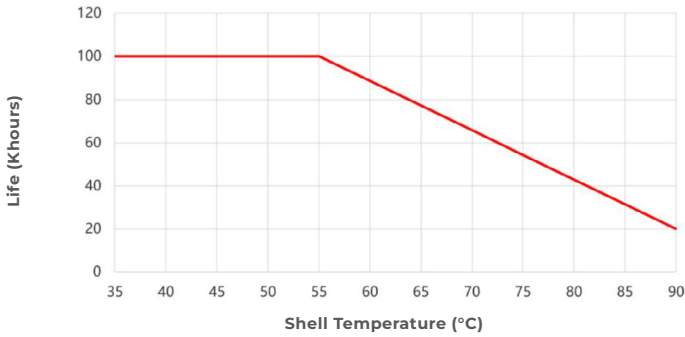

**0-10V DIMMING CURVE**

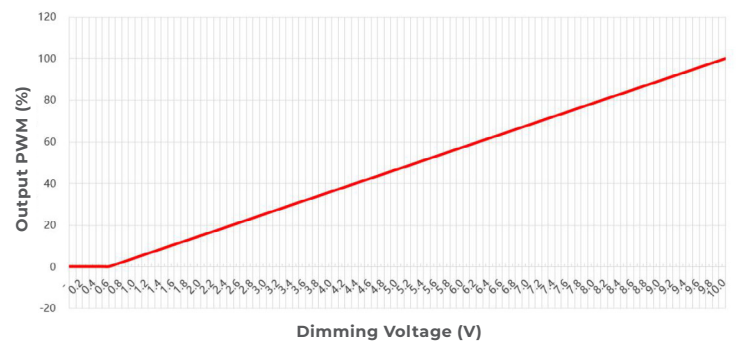

**THD - OUTPUT POWER CURVE**

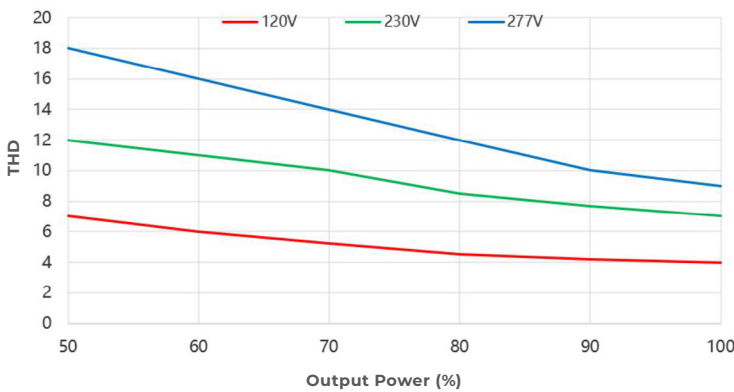

**RESISTANCE DIMMING CURVE**



**MECHANICAL SPECIFICATION**

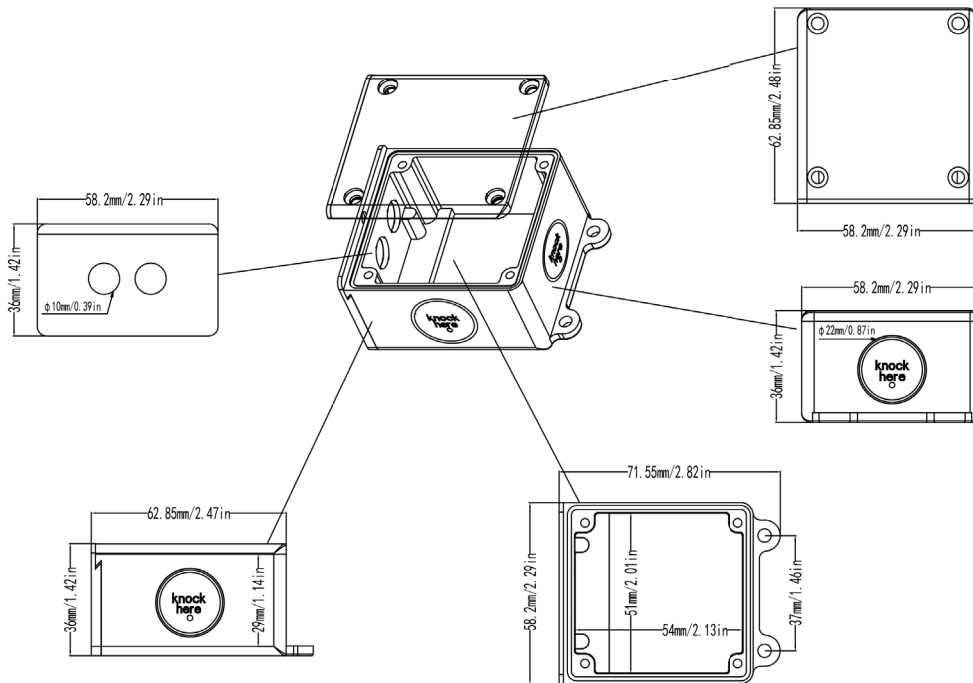
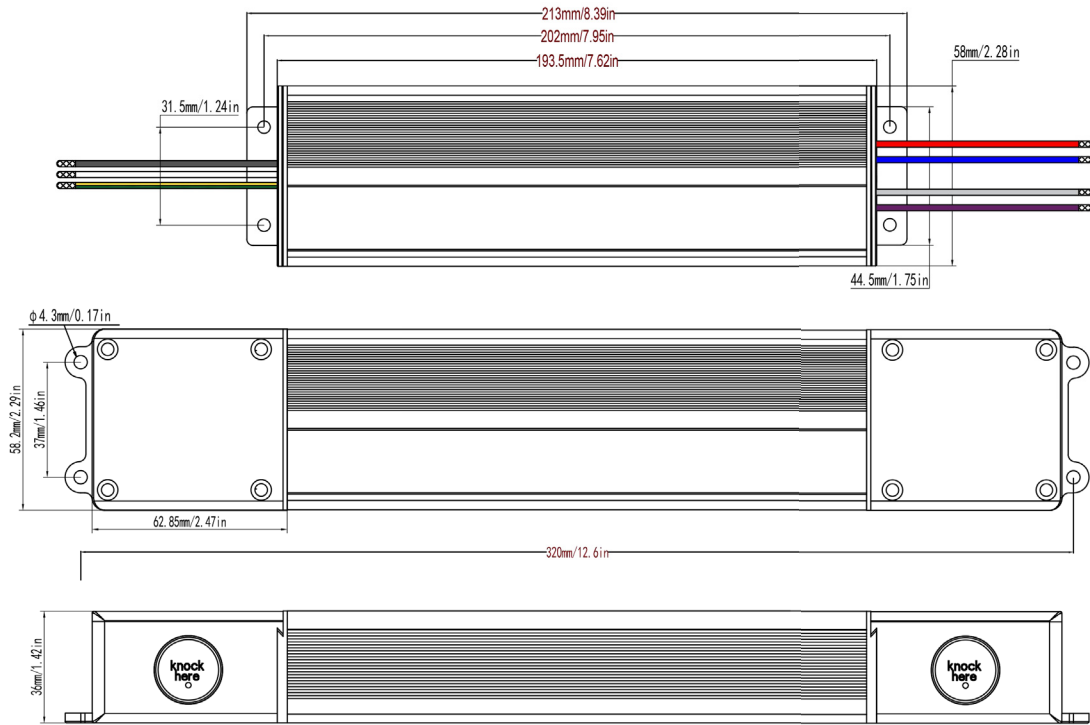

**Notes:**

1. Input Cable: UL 1015# 18AWG ØD: 2.75mm, Green: Ground, Black: L, White: N.
2. Output Cable: UL 1015# 18AWG ØD: 2.75mm, Red: V+, Blue: V-, Single wire.
3. Dimming Cable: UL 1015# 18AWG ØD: 2.75mm, Purple: dimmer signal (+), Grey: dimmer signal (-).