



# DUNTON HOUSE

## DECORATIVE LIGHTING

### LEWIS-MP MINI PENDANT E12 CABLE + STEM

PROJECT \_\_\_\_\_ DATE \_\_\_\_\_

COMMENTS \_\_\_\_\_



#### PHYSICAL

Material	Metal
Lens Material	Outer Clear Glass, Inner Frosted Glass
Mounting	Suspended C: 38.25" Adjustable Cable, S: 2 x 12", 2 x 6" Stems
Finish	Black, Brushed Nickel, Black + Gold
Source	1 x E12, Type B Shape Recommended (4W 350lm 3000K Dimmable LED Lamp Included)
Dimensions	D Ø3.5" x H 8"

#### PERFORMANCE

Warranty	5 years
Certifications	cETLus
CCT	3000K
CRI	90
Lamp Lumens	350lm per lamp

#### ELECTRICAL

Wattage	60W Type B Maximum Per Socket
Voltage	120V
Dimmable	Yes, with dimmable lamp and dimmable switch. Dimmable switch not included.

#### NOTES

Usage	Indoor Only
-------	-------------

#### ORDERING LOGIC

EX: LEWIS-MP-C-BK

FAMILY	TYPE	MOUNTING	FINISH
<b>LEWIS</b>	<b>MP</b>		
	<b>MP</b> Mini Pendant	<b>C</b> Cable	<b>BK</b> Matte Black
		<b>S</b> Stem	<b>BN</b> Brushed Nickel
			<b>BKGD</b> Black + Gold



WITH CABLE



WITH STEM

#### DIMENSIONS

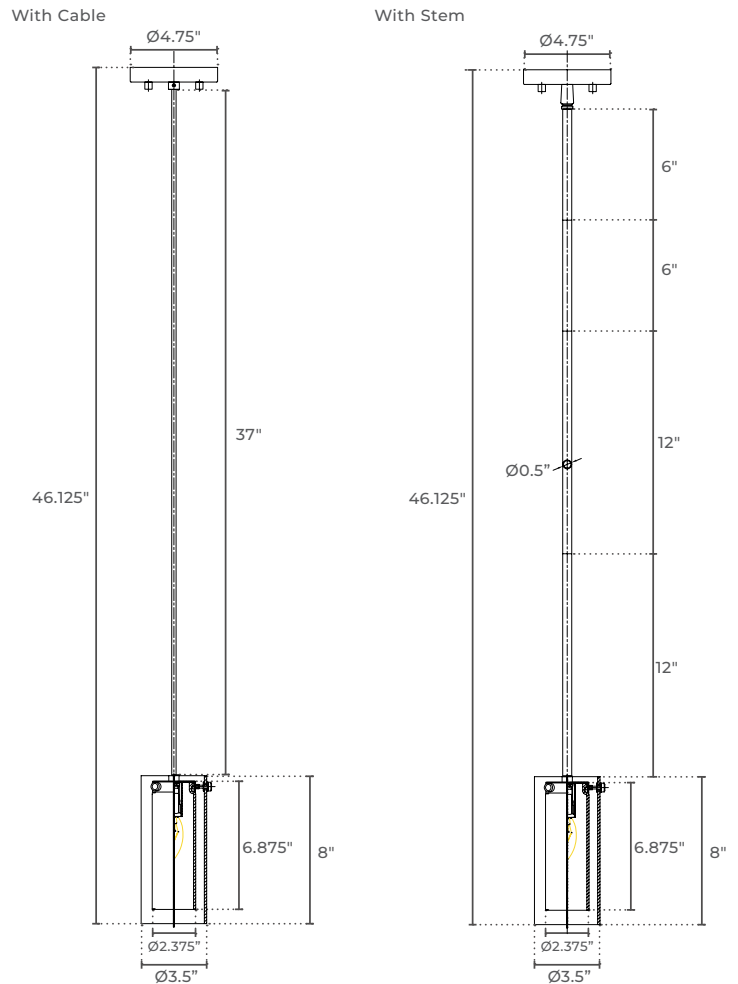

**LEWIS FAMILY**

**LEWIS-WL**  
EXTERIOR SCONCE E12



**LEWIS-1**  
VANITY E12



**LEWIS-2**  
VANITY E12



**LEWIS-3**  
VANITY E12



**LEWIS-4**  
VANITY E12



**LEWIS-C**  
CHANDELIER E12 CHAIN + STEM



**ADDITIONAL IMAGERY**

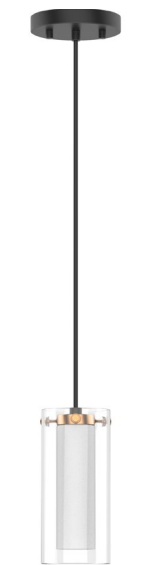

**DROP-MP-C-BK**



**DROP-MP-S-BN**



**DROP-MP-C-BK**



**DROP-MP-S-BN**

