

PROJECT DATE

COMMENTS



ENERGY CHART

SPEED	MIN	MAX
Power (W)	13	53
Current (A)	0.22	0.44
Rotation (RPM)	75	180
Airflow (CFM)	1100	4500

ORDERING LOGIC EX: TERN-44-BK-BK

FAMILY	SIZE	HOUSING FINISH	BLADE FINISH
TERN	44 44"	BK Black	BK Black
	52 52"	SN Satin Nickel	SN Satin Nickel

TERN CEILING FAN LED

Tern is a three blade indoor ceiling fan available in 44" and 52". Tern is supplied with a 3000K light kit and a remote control.

- Residential
- Commercial
- Hospitality

PHYSICAL

Material	Metal
Blade Material	3 Plywood Blades
Lens Material	Acrylic
Mounting	Surface
Fan Diameter	44", 52"
Source	LED
Finish	Black, Satin Nickel
Sloped Ceiling Accommodation	Yes

PERFORMANCE

Warranty	10 years for motor, 1 year for light kit, & 2 years for blade housing, and cap
Certifications	Dry Location, UL
CCT	3000K
Delivered Lumens	1600
Reversible	Yes
Dimmable	Triac

ELECTRICAL

Light Kit Wattage	19W
Motor Wattage	55W
Total Wattage	74W
Voltage	120V
Motor	AC Motor 120V/60Hz (153x13mm)
Controls	Remote Control (Included)

ACCESSORIES ORDERING LOGIC EX: WS (ORDER SEPARATELY)

ACCESSORIES
WS Combination Fan Speed Dimmer Wall Switch CLICK HERE FOR ACCESSORY SPECIFICATION SHEET



DIMENSIONS

SIZE 44

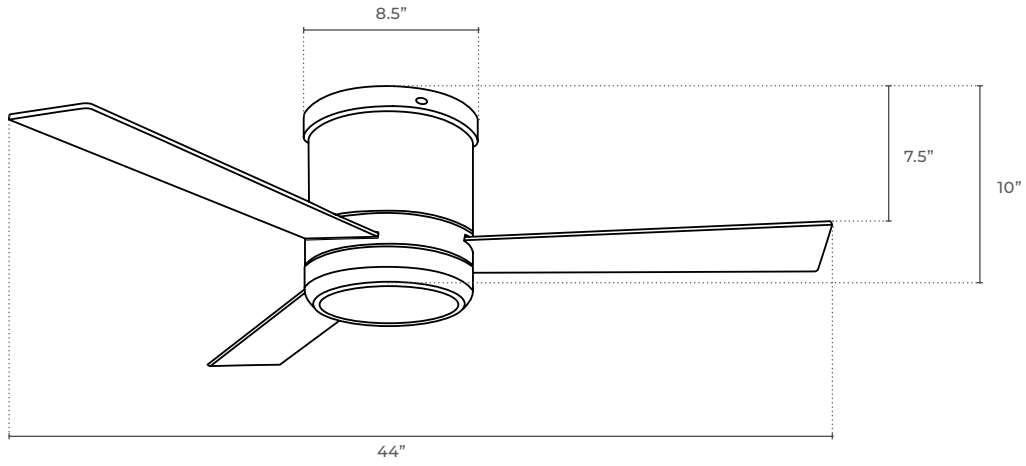

SIZE 52

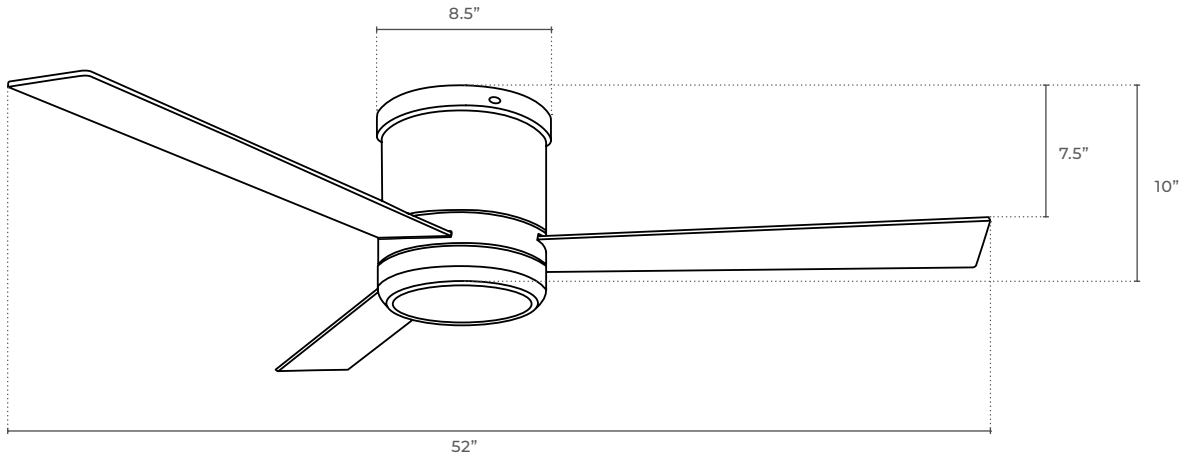

FINISH OPTIONS

HOUSING FINISHES



BLACK

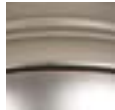

SATIN NICKEL

BLADE FINISHES



BLACK



SATIN NICKEL

CONTROLS

REMOTE CONTROL



WALL CONTROL

WS FAN AND LIGHT WALL CONTROL

